

The Weevil is built around two simple & lofi squarewave oscillators. These oscs are made out of digital chips but implemented in a very analogue manner. By using digital chips we can easily add a second circuit block to combine the two waveforms using an XNOR gate, a process that sounds very much like ring modulation. A similar circuit has actually been used in cymbal synthesizers, but in this case it is preferred to let out the full voice of the circuit. A powerful little low-pass filter has been added before the output to tame the high-energy-high-frequencies.

The AudioWeevil furthers the Weevil design by allowing audio processing – an audio input is turned into a squarewave using a comparator and this signal can then be combined with the Weevils internal signals. OscA can be knocked out and replaced with the squared input to give harsh ringmod sounds or overdriven tremolo.

The copper contact plates on top of the Weevil, combined with the extremes offered by the low power circuitry, create a unique playing interface that requires experimentation.

Oscillators: Each osc has a pitch dial and a two-way pitch range switch giving a range from sub-audio clicks, through squarewave tones and up into supra-frequencies. Begin with the Mode Switch switched to Osc – you will hear the ringmodulated oscillator tones. Switching to Audio Input mode without an audio input signal simply knocks out OscA so you get the pure tones of OscB.

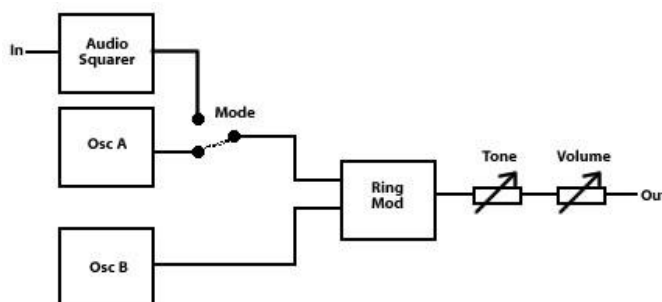

Audio Input: The audio input control behaves in a slightly strange manner. Switch to Audio Mode and connect an input signal – this will work with low-level signals (such as guitar or mic) or higher line-level signals. Begin with the Audio dial set to a middle position – with OscB set to LoFreqs you should hear overdriven tremolo effects, while the HiFreq setting gives harsh ringmod sounds. Turning the Audio dial either way from its central position will introduce a gating effect on the input – experiment to find the best setting and investigate the sonic possibilities.

Low Power Dial: This knob places a resistance across the battery power supply, simulating the battery running out of juice and causing the circuit to spit out malfunctions. Fully clockwise gives full power supply. The low power feature does not work very well with the audio input unfortunately.

Power: Ensure the battery is fitted correctly before switching on the power. This device is battery only and should not be used with other power supplies.

Connections: Input and output are both on ¼" mono jack. There is no input level control as the input comparator will react fine with low-level signals. The output signal can be loud so start with the volume down.

Body Contact Plates: The response of these copper plates depends on how moist your fingers are - try licking your fingertips – and how hard you press (governing how large an area of contact you are making). Plates often function in conjunction with others – try combinations.

- **Plates A & Plates B:** Each oscillator has three contact points – bridging between plates will cause various modulations of the oscillator pitches.
- **Plates G:** The circuit ground connection - bridging between an oscillator and this plate will generally lower the pitch.
- **Plate I:** Connection for the squared audio input – this point is active even if the mode is switched to Osc.
- **Plate R:** The ring-mod output. Connecting this back into the oscillators can make things go haywire causing canceling and cross-modulation.

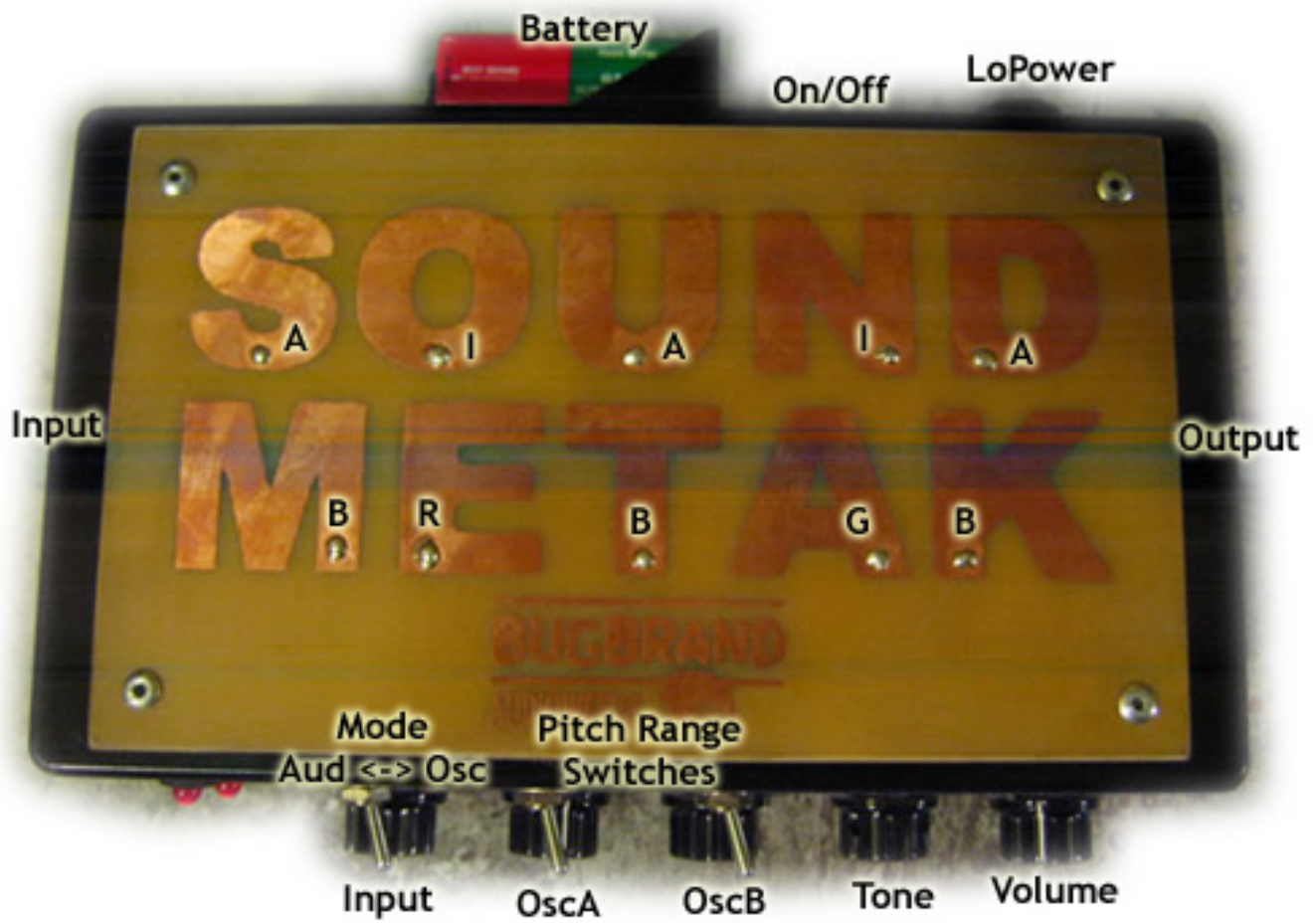

MetakAudioWeevil - ref. AudioWeevil manual::
http://bugbrand.co.uk/manuals/audioweevil06_instructions.PDF